

SkillsUSA

CALIFORNIA

STATE CONTEST

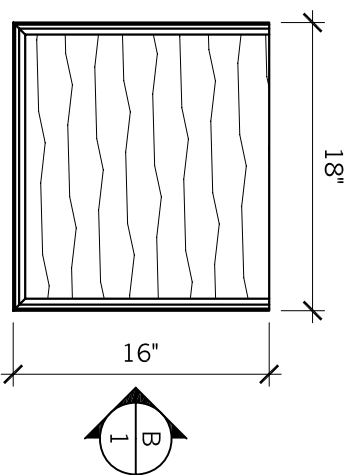

PLAN
SCALE: 1"=1'-0"

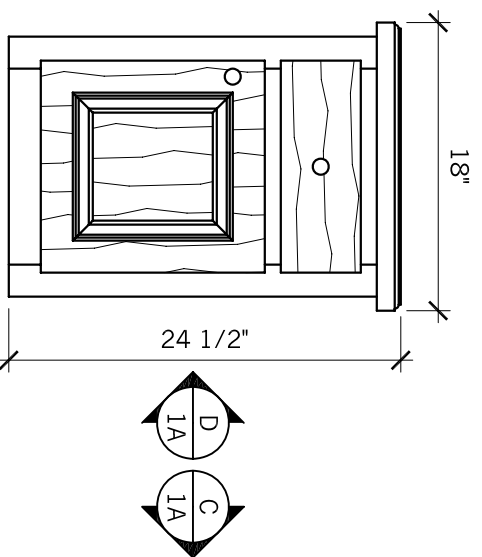

A ELEVATION
SCALE: 1"=1'-0"

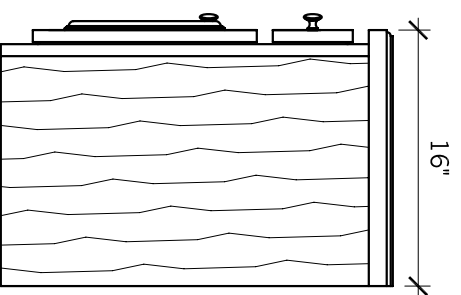

B ELEVATION
SCALE: 1"=1'-0"

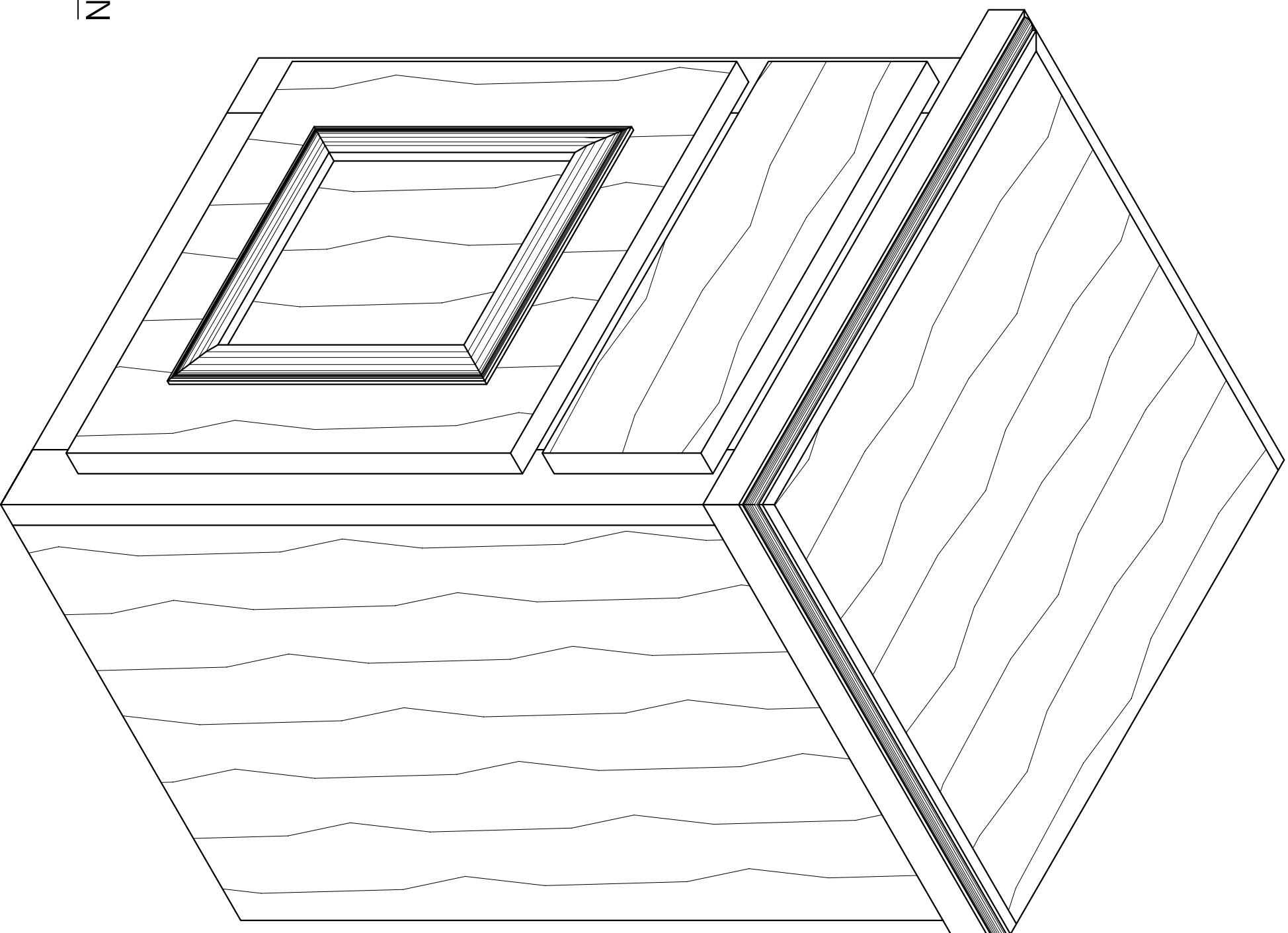

- HARDWARE:
- 1 - PAIR OF KV DRAWER SLIDES
 - 1 - PAIR OF BLUM 1/2" OVERLAY HINGES W/ PLATES
 - 2 - AMEROCK KNOBS
 - 4 - 1/4" SHELF PINS

SkillsUSA
CALIFORNIA
STATE CONTEST

ITEM:	Wood Cabinet
DATE:	2/20/13
SCALE:	AS SHOWN
DRAWN BY:	ES/SM
COMpetition DATE:	4/6/2013
DWG #:	1

SPECIAL SPONSORS:



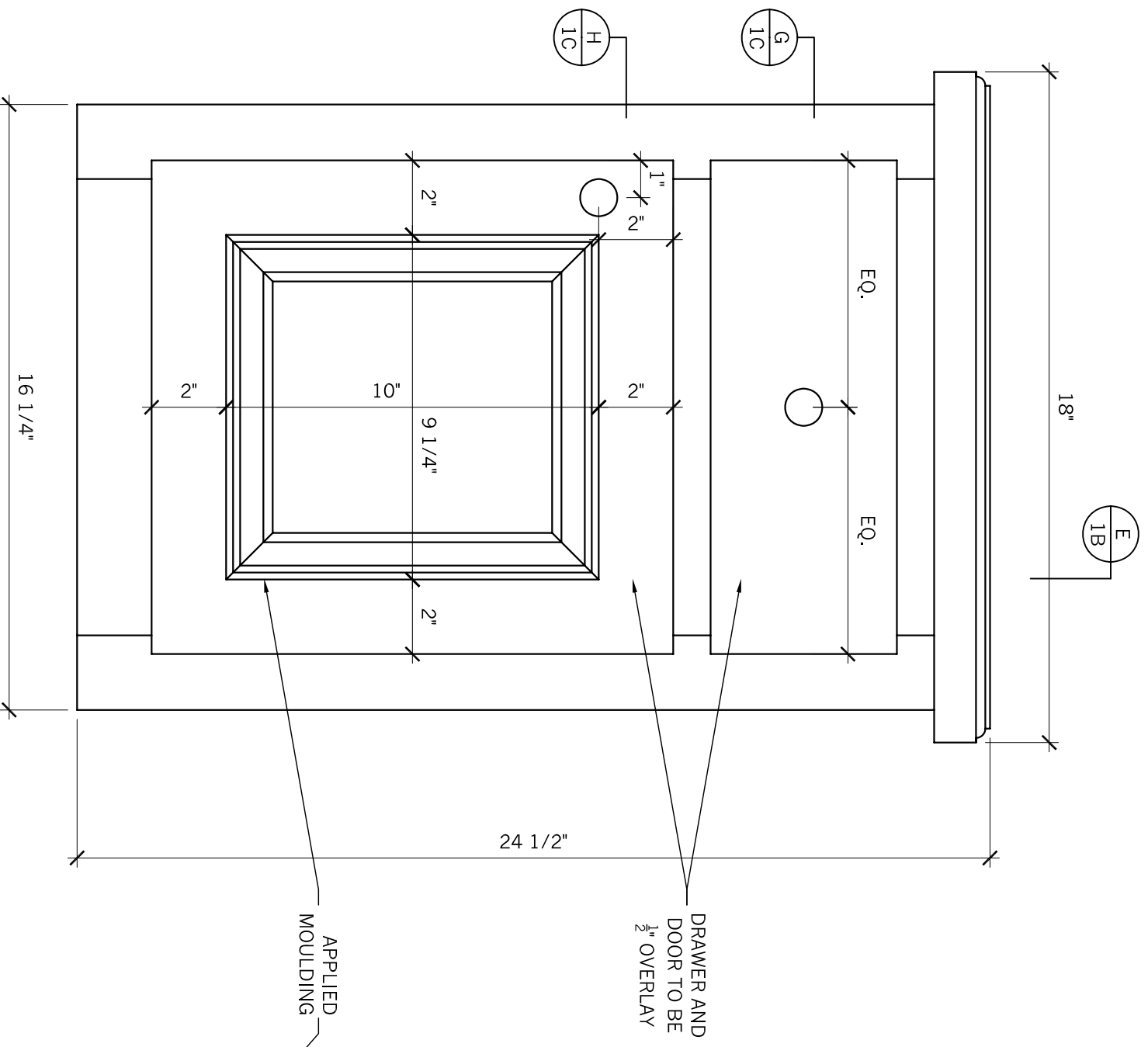

C
ELEVATION
SCALE: 3"=1'-0"

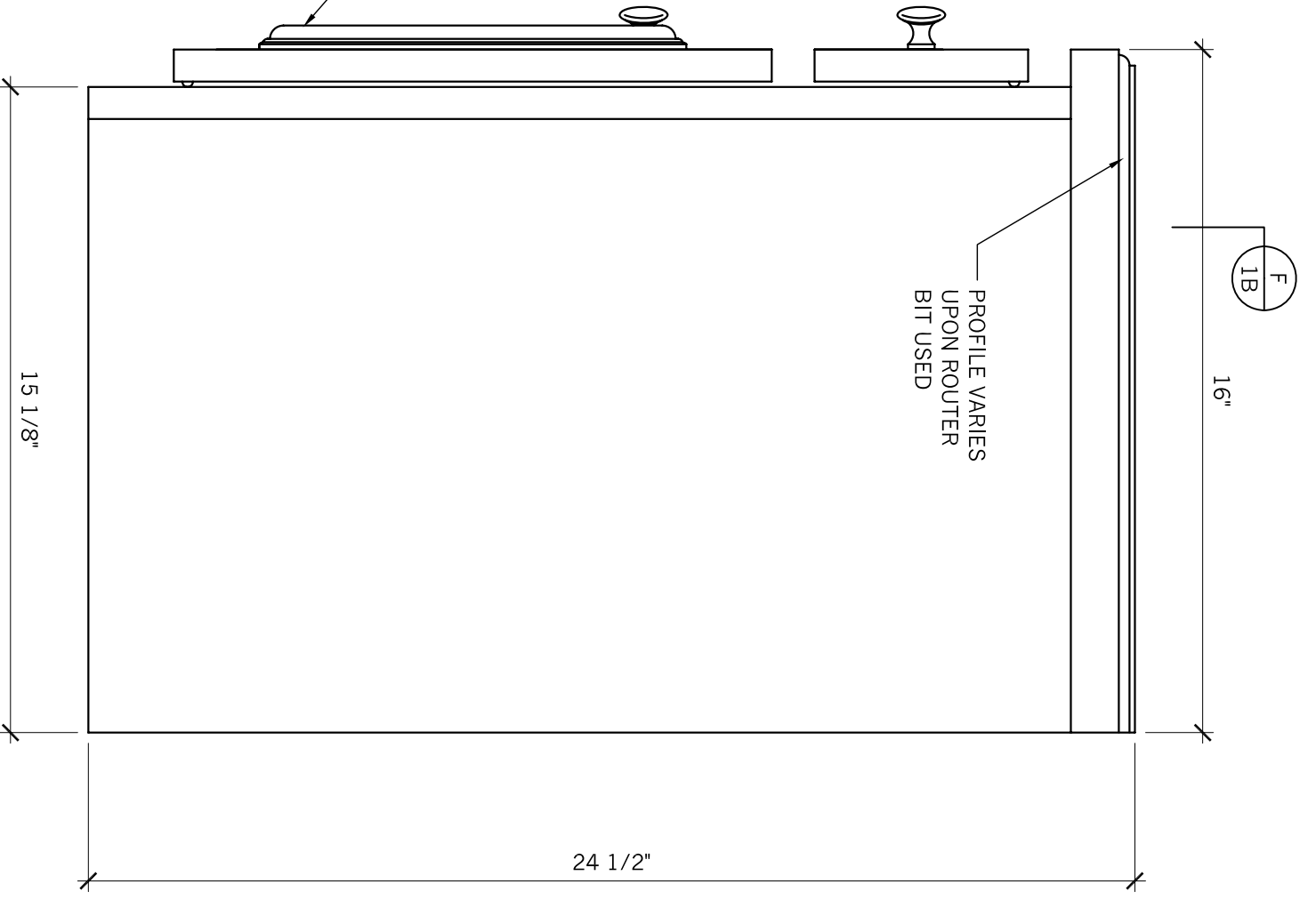

D
ELEVATION
SCALE: 3"=1'-0"

SkillsUSA
CALIFORNIA
STATE CONTEST

ITEM: Wood Cabinet

DATE: 2/20/13 COMPETITION DATE: 4/6/2013

SCALE: AS SHOWN DWG #: 1A

DRAWN BY: ES/SM

SPECIAL SPONSORS:

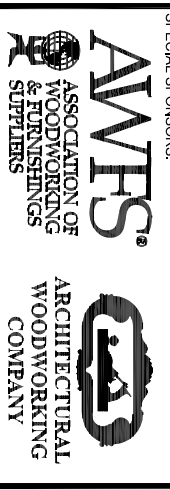

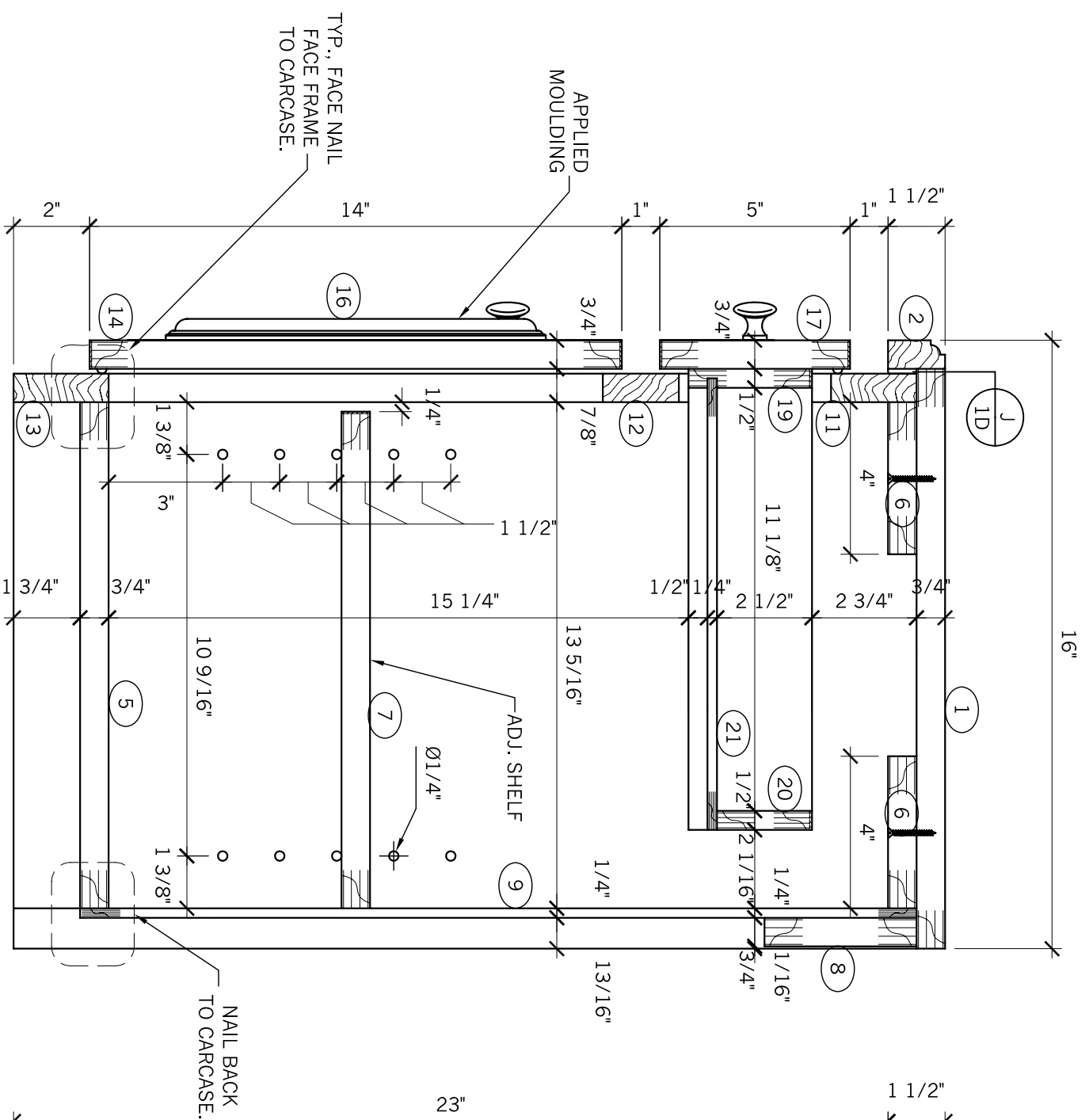

E VERT SECTION
SCALE: 3"=1'-0"

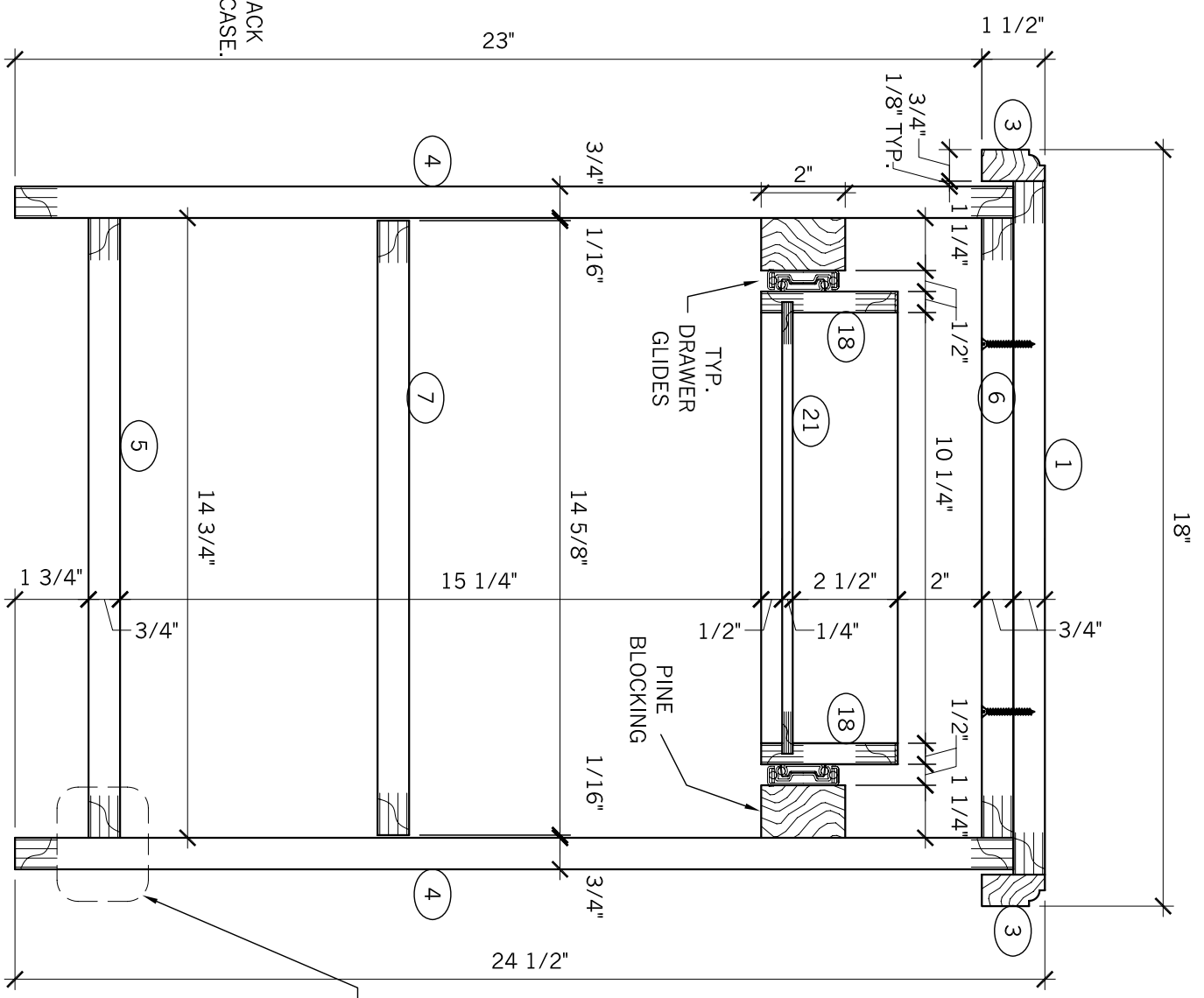

F VERT SECTION
SCALE: 3"=1'-0"

TYP., USE BISCUITS FOR ALIGNMENT & FASTEN W/ POCKET SCREWS.

SkillsUSA
CALIFORNIA
STATE CONTEST

ITEM: Wood Cabinet

DATE: 2/20/13 COMPETITION DATE: 4/6/2013

SCALE: AS SHOWN DWG #: 1B

DRAWN BY: ES/SM

SPECIAL SPONSORS:

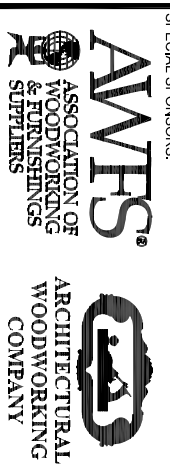

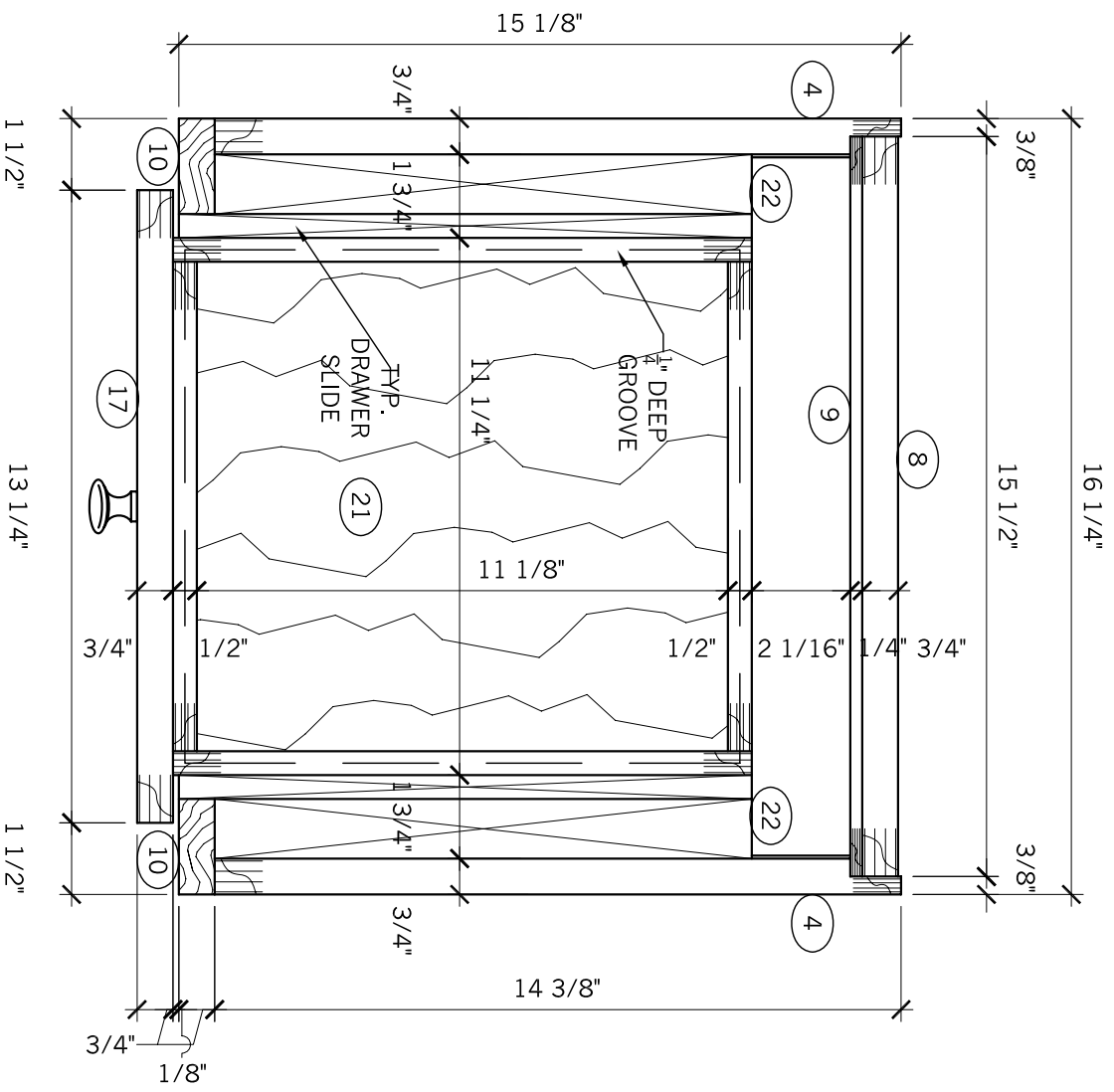

G PLAN SECTION
SCALE: 3"=1'-0"

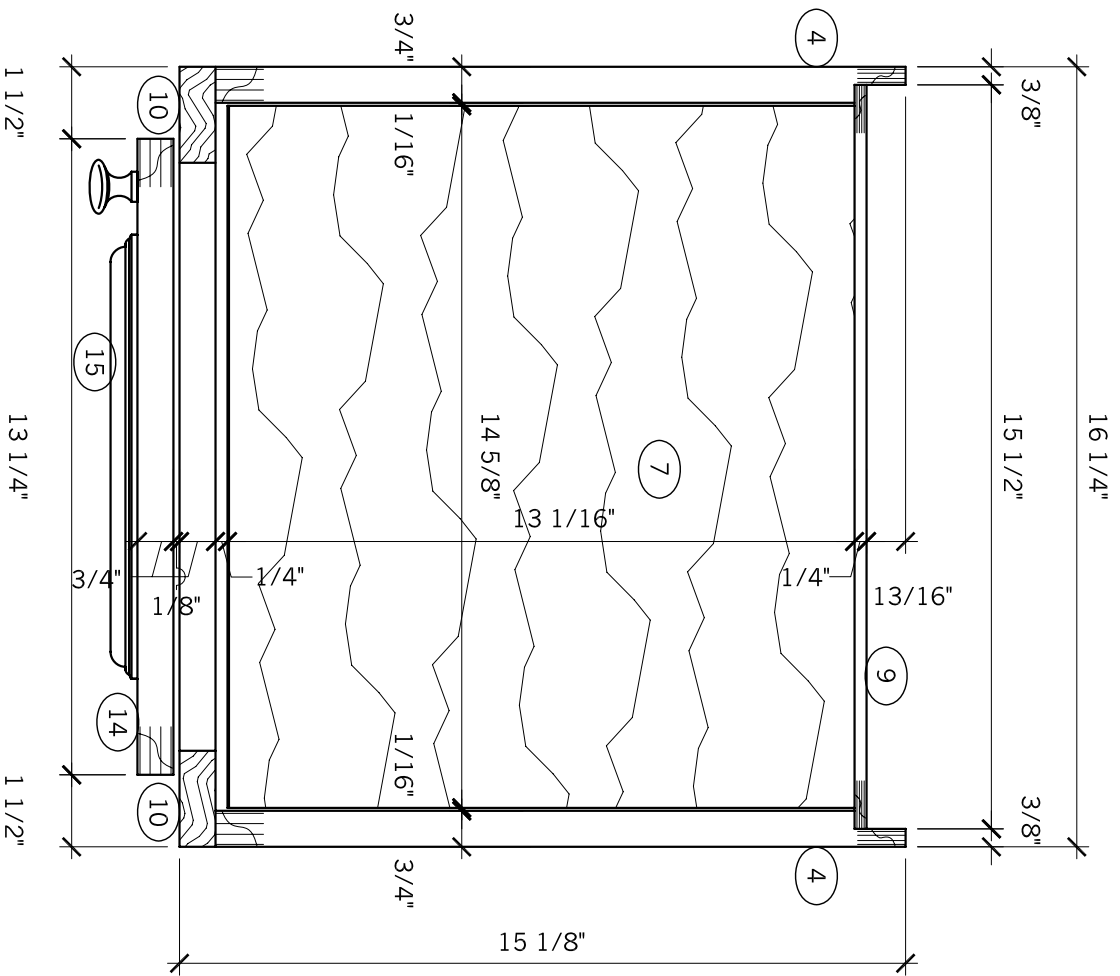

H PLAN SECTION
SCALE: 3"=1'-0"

SkillsUSA
CALIFORNIA
STATE CONTEST

ITEM: Wood Cabinet

DATE: 2/20/13 COMPETITION DATE: 4/6/2013

SCALE: AS SHOWN DWG #: 1C

DRAWN BY: ES/SM

SPECIAL SPONSORS:

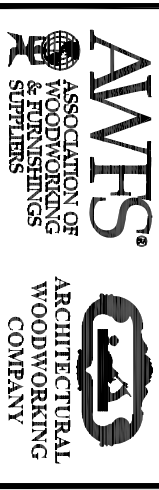

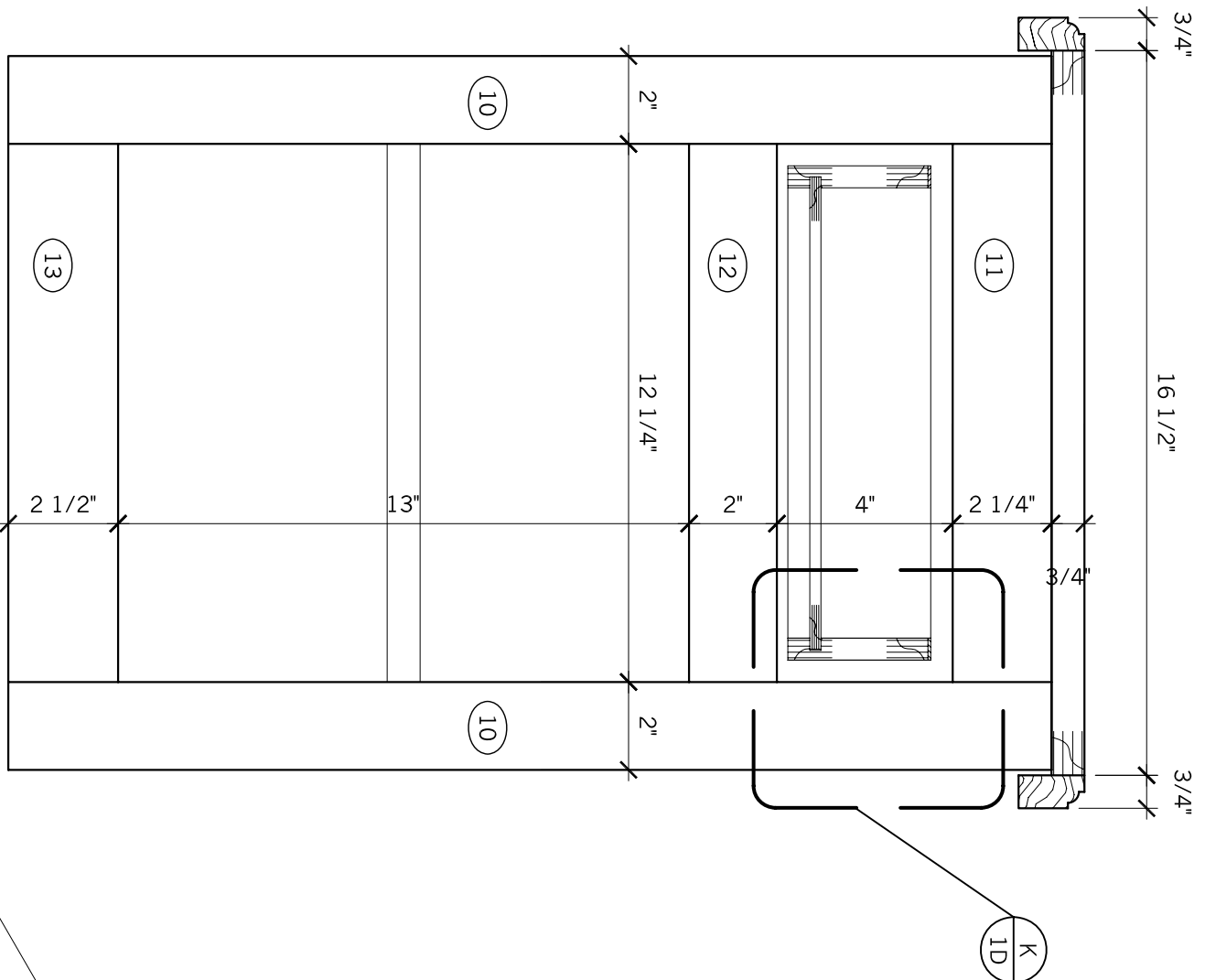

J
LONGIT SECTION
SCALE: 3"=1'-0"

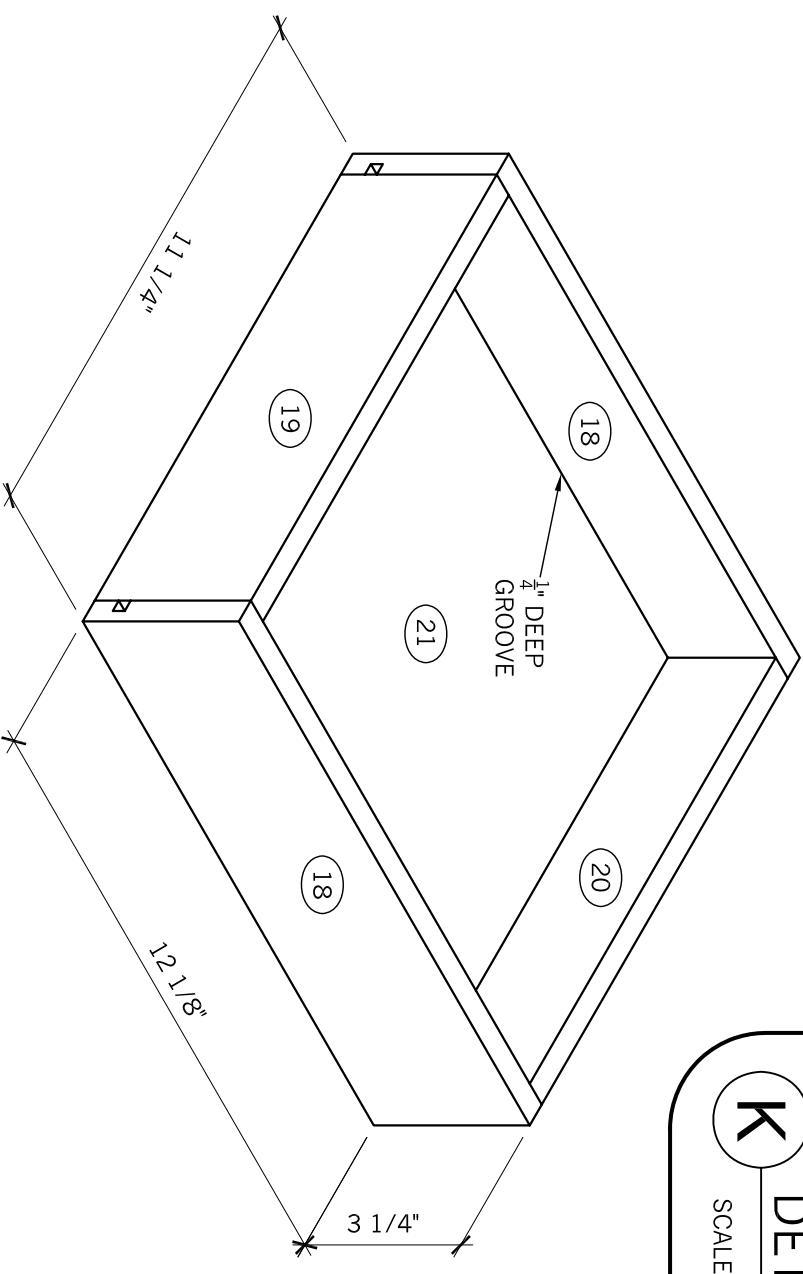

DRAWER BOX
ISOMETRIC: N.T.S.

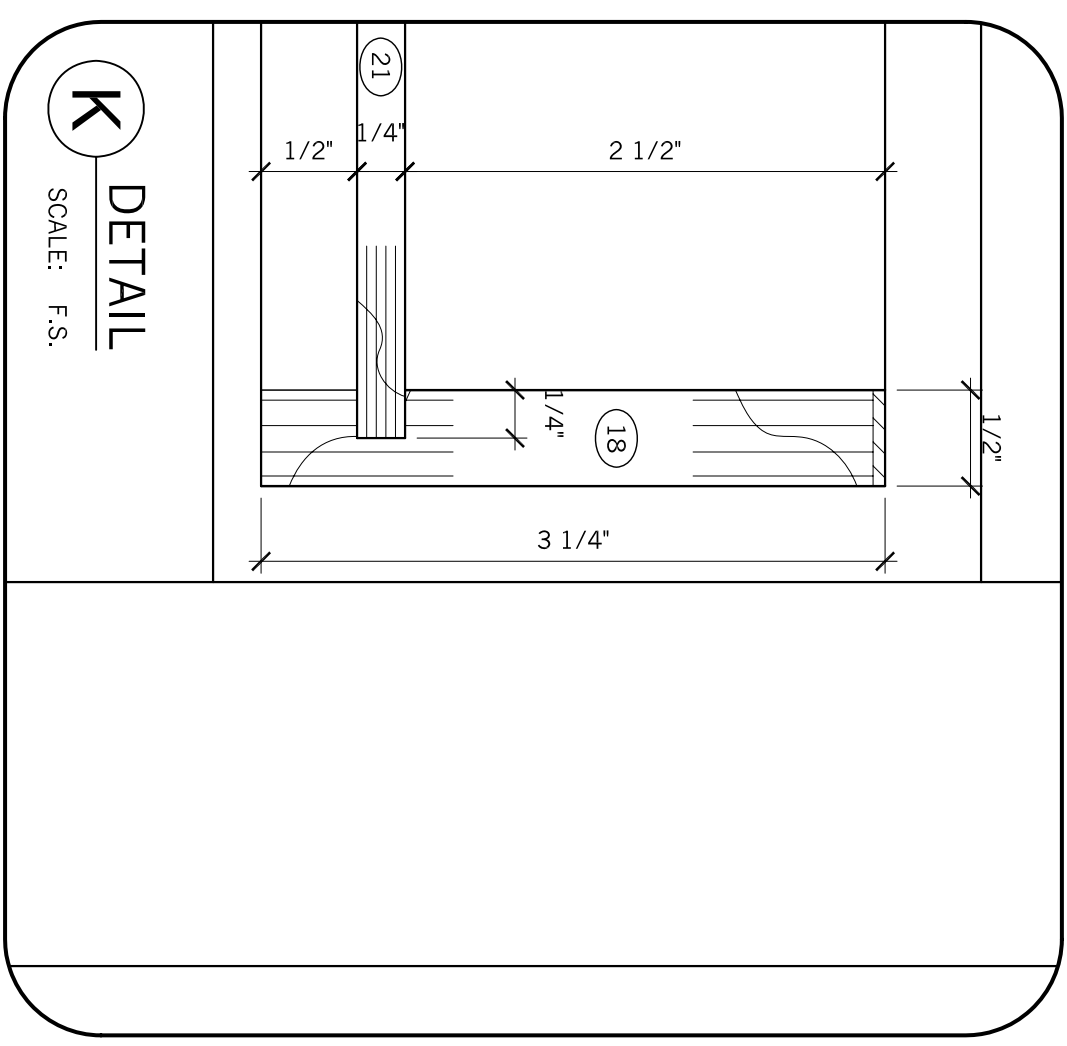

K
DETAIL
SCALE: F.S.

SkillsUSA
CALIFORNIA
STATE CONTEST

ITEM:	Wood Cabinet
DATE:	2/20/13
SCALE:	AS SHOWN
DRAWN BY:	ES/SM
COMPETITION DATE:	4/6/2013
DWG #:	1D

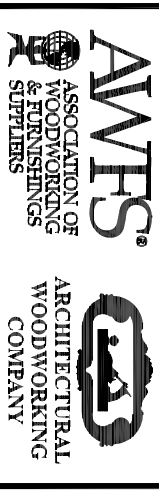

CONTESTANT # _____

BILL OF MATERIALS

NOTES: _____

#	✓	QTY	DESCRIPTION	MATERIAL	THICKNESS	WIDTH	LENGTH	NOTES
1		1	Top	Red Oak Ply	$\frac{3}{4}$ "	$15\frac{1}{4}$ "	$16\frac{1}{2}$ "	
2			Front Build-Up	Solid Red Oak				
3			Side Build-Up	Solid Red Oak				
4		2	Ends	Red Oak Ply	$\frac{3}{4}$ "	$14\frac{3}{8}$ "	$23\frac{3}{4}$ "	Rab. 1 Long
5			Bottom	Red Oak Ply				
6			Stretchers	Red Oak Ply				
7			Adj. Shellfr	Red Oak Ply				
8			Cabinet Cleat	Red Oak Ply				
9			Back	Red Oak Ply				
10			Stiles	Solid Red Oak				
11			Top Rail	Solid Red Oak				
12			Mid Rail	Solid Red Oak				
13			Bottom Rail	Solid Red Oak				
14			Door	Red Oak Ply				
15			Door Molding	Solid Red Oak				
16			Door Molding	Solid Redd Oak				
17			Drawer Front	Red Oak Ply				
18			Drawer Sides	Red Oak Ply				
19			Drawer Front	Red Oak Ply				
20			Drawer Back	Red Oak Ply				
21			Drawer Bottom	Red Oak Ply				
22		2	Blocking	Pine	$1\frac{1}{4}$ "	2"	$11\frac{1}{4}$ "	

SkillsUSA
 CALIFORNIA
 STATE CONTEST

ITEM: Wood Cabinet

DATE: 2/20/13 COMPETITION DATE: 4/6/2013

SCALE: AS SHOWN DWG #: B. of M.

DRAWN BY: ES/SM

SPECIAL SPONSORS:

